

STEELCRAFT®

A16-SERIES STILE AND RAIL DOORS



ABOUT THE PRODUCT:

The A16-Series Doors are designed to meet the architectural requirements for Stile and Rail doors. The stiles extend the full height of the door. The tubular stiles and rails are mechanically joined to the stiles to form a neat seam on the face of the door.

The A16-Series doors are available for high frequency openings and entrances where large full glass (FG, FG2, and FG3) lites are required.

To meet application, specification and performance requirements, the A16-Series doors offer a wide range of specifiable options including sizes, glass lite designs, and hardware preparations.

FEATURES AND BENEFITS:

Steelcraft's A-Series Doors offer the following standard unique features which not only enhance long term performance and durability.

1. **Tubular stile and rail construction** provide support for large glass lites.
2. **Patented universal hinge preparations** allow for easy field conversion from standard weight (.134) hinges to heavy weight (.180) hinges.
3. **14 gage** top and bottom channels provide stability and protection for the top and bottom edges from abuse.
4. **Beveled hinge and lock edges** with no visible edge seams allow for tighter installation tolerances, ensure easier operation, and eliminate binding and sticking.
5. **Factory applied baked on rust inhibiting primer** in accordance with ANSI A250.10.

SPECIFICATION COMPLIANCE:

1. Door construction for the Steelcraft A16-Series Stile and Rail Doors meet the requirements of ANSI A250.8-1998 (commonly referred to as SDI-100).
2. Hardware preparations and reinforcements are in accordance with ANSI A250.6-1997. Locations are in accordance with ANSI DHI A115.
3. Door construction for the Steelcraft A16-Series Stile and Rail doors meet ANSI A117.1-1998 (ADA) requirements for minimum 10" bottom rail height measured from floor.

FIRE RATINGS:

The A16-Series doors meet fire rating requirements. They are listed for installations requiring compliance to both negative pressure testing (ASTM E152 and UL-10B) and positive pressure standards (UBC 7-2 and UL-10C).

Steel Thickness	Opening	Usage Frequency ¹	Frame Applications
16 gage (1.3mm)	Interior & Exterior	Heavy to Extra-heavy duty	• 16 & 14 gage steel frames
Steel Type	Opening	Building Applications	
Non Galvannealed ³	Mainly Interior	• Typical building conditions	
Galvannealed ²	Mainly Exterior	• Used in locations with high humidity and/or weather exposure	

MATERIAL:

Depending on environmental conditions, exterior doors are generally galvannealed and interior doors non galvanneal. All doors are supplied with a factory applied baked on primer for field applied finish paints.

¹ Usage frequency is based on ANSI A250.8-1998
² Reinforcements for galvannealed doors are also galvannealed
³ Commercial quality carbon steel

Details are subject to change without prior notice.

© 2000 Steelcraft Co.
 Printed in USA

IR Security & Safety®
 Proven Source. Proven Solutions.™

Spec Manual
 Rev. 5/2002

A1-1

STILE & RAIL DOORS

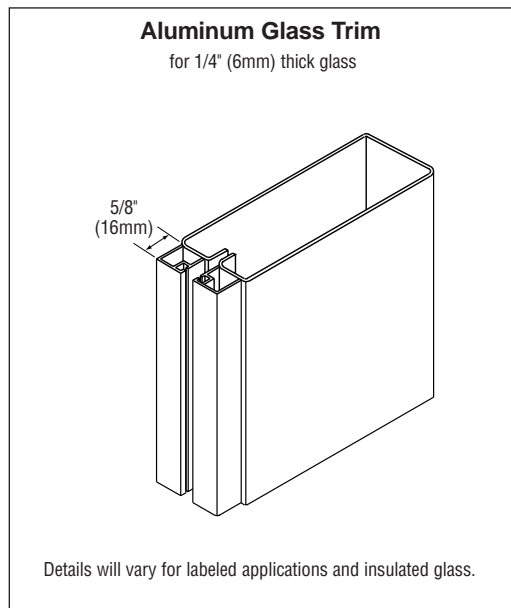
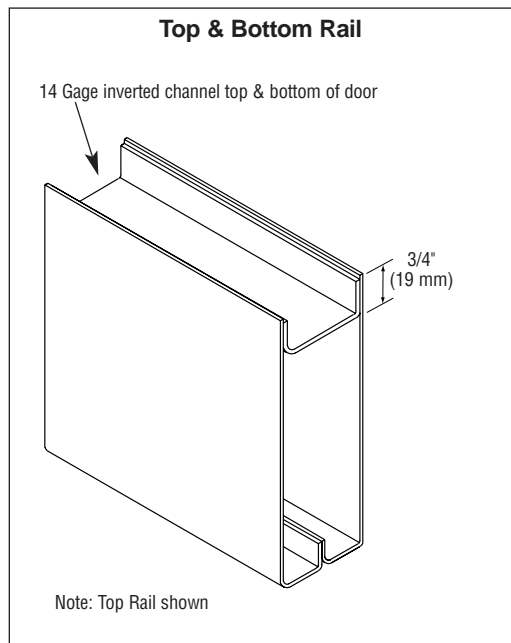
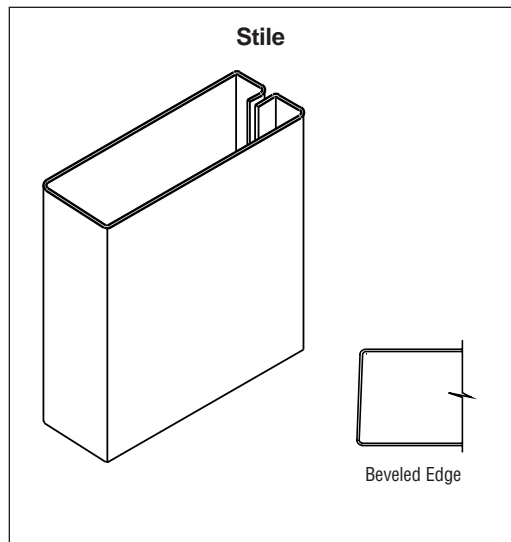
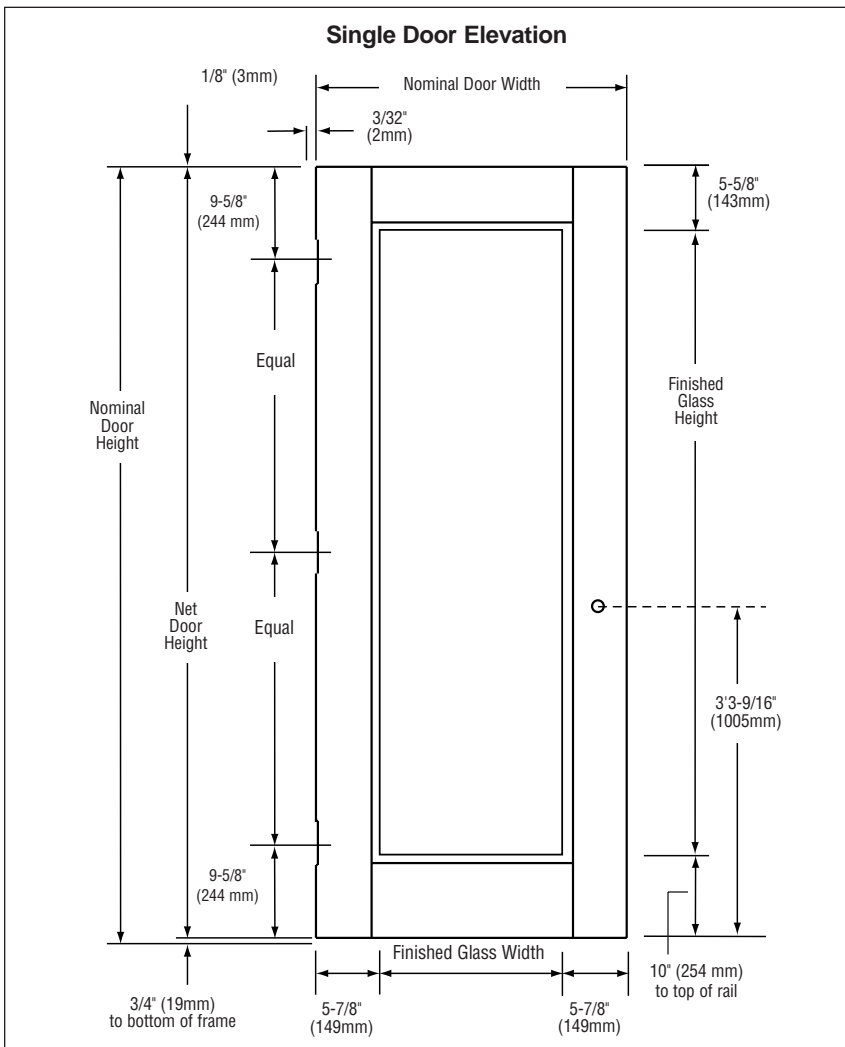

CONSTRUCTION NOTES:

- Doors** are 1 3/4" (45mm) thick.
- Door opening size maximum:**
Single door opening size 4'0" x 8'0" (1219mm x 2438mm)
Double door opening size 8'0" x 8'0" (2438mm x 2438mm)
- Standard operating clearances** (*installed in frame*):
Head = 1/8" (3mm) to bottom of head or transom panel
Hinge and lock side = 3/32" (2mm) to rabbet on jamb
Bottom = 3/4" (19mm) to bottom of frame
- Standard construction:**
 - Top and bottom channels – 14 gage
 - Stiles – 16 gage tubular construction:
5 1/4" (133mm) face dimensions (5 5/8" [143mm] with glazing bead)
 - Rails – 16 gage construction:
5" (127mm) top rail face dimensions (5 5/8" [143mm] with glazing bead)
10" (254mm) bottom rail face dimensions (10 5/8" [270mm] with glazing bead)
 - Intermediate rails (FG3 & FG3) – 16 gage construction:
5" (127mm) mid rail face dimensions (6 1/4" [158mm] with glazing bead)
- Hardware preparations:** to meet specifications, doors can be prepared for all commercial mortised hardware, and can be factory reinforced for surface applied hardware applications.
 - Lock preps** – details and dimensions shown are for cylindrical (ANSI 115.2) type locks. For mortise (ANSI 115.1) locks, the centerline of the lock is located 3/8" (9mm) lower.
- Glass lites and louvers:** doors with glazed cutouts and doors with louvers are available.

STILE & RAIL DOORS

Universal Mortise Hinge Prep
4½" – Standard 5" – Optional

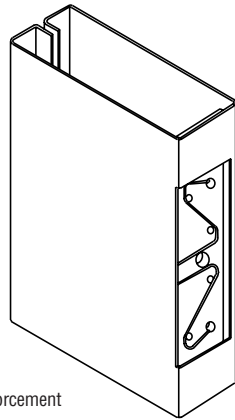

7 Gage Hinge Reinforcement

Optional Screw-In Top Cap

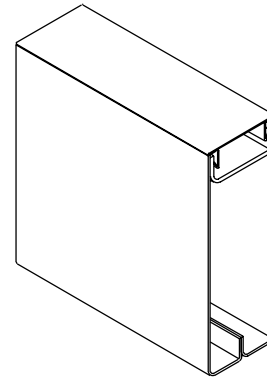

GENERAL NOTES:

1. Edge construction:

- Vertical edges (both hinge and lock) are beveled.
- Top and bottom edges are closed with inverted 14 gage welded channels. Exterior applications require the addition of snap-in top caps to protect against the weather.

2. Stile and Rail attachment:

- The tubular stiles and rails are mechanically joined to the stiles to form a neat seam on the face of the door.

3. Standard hardware preparations: standard mortised and reinforced for:

- **Universal hinge preps** – 4½" (114mm) patented preparation which allows easy and quick field conversion from standard to heavy weight hinges.
- **Locks** – A multitude of standard lock preps are available. The most commonly used with a 4⅞" (124mm) strike are 161, 61L and 86.

Lock Prep

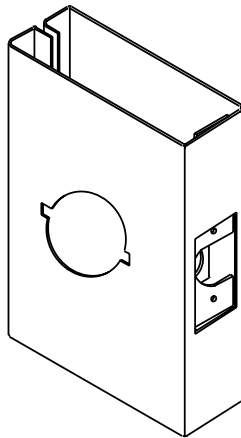

161 Cylindrical Lock shown

Optional 14 Gage Closer Reinforcement

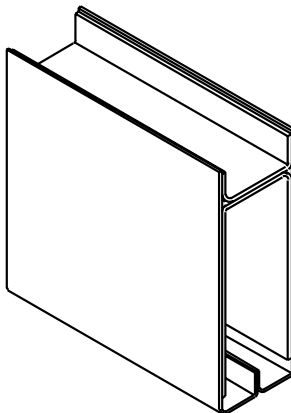

Intermediate Rail Section

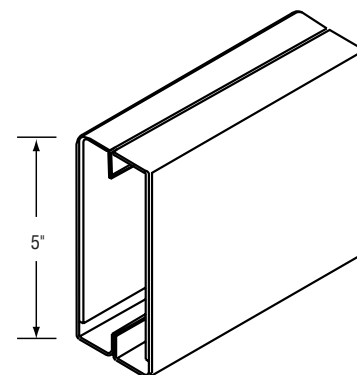

STILE & RAIL DOORS

INSTALLATION:

1. Installation shall conform to the published Steelcraft installation instructions, SDI 105 *Recommended Installation Instructions for Steel Frames*, and ANSI/DHI A115-IG *Installation Guide for Doors and Hardware*.
2. Fire Rated Assemblies must be in accordance with NFPA Pamphlet 80. The *Authority Having Jurisdiction* is the final authority in issues related to the installation and use of installed Fire Rated Door.

DOOR APPLICATIONS:

The A-Series Doors are used in virtually all buildings and construction applications. They are specifically designed as entrance doors.

CONVERSION CHART

ANSI A250.8 (SDI 100) *Recommended Specification for Standard Steel Doors and Frames*.

Series	Level	Model	Description	Edge Construction
A16	3	3	Stile & Rail	Tubular – No seams

DOUBLE DOOR APPLICATIONS:

A-Series doors are available in double door elevations, with active and inactive leaves and an overlapping astragal.

- **Standard operating clearances** (*installed in frame*):
 - Head = $\frac{1}{8}$ " (3mm) to bottom of head or transom panel
 - Hinge side = $\frac{3}{32}$ " (2mm) to rabbet on jamb
 - Meeting edges = $\frac{3}{32}$ " (2mm) with or without astragal. For openings without an astragal, a wide inactive leaf is used.
 - Bottom = $\frac{3}{4}$ " (19mm) to bottom of frame

- **Meeting edges:**

- 14 Gage astragal is furnished loose for installation in the field by others.
- Overlapping astragal kits are available to convert an active leaf to an inactive leaf.
- When an astragal is not used, the width of the inactive leaf is increased $\frac{3}{32}$ " (2mm).
- **Hardware preparations:** the inactive leaf can be prepared for hardware as specified.

MEETING EDGE DETAILS:

